



# STANDARD FLAKE PACKAGING UPDATE

EFFECTIVE: MAY 15, 2020

## IMPLEMENTATION OF 40 LB UNIT

Effective **May 15, 2020**, all standard TORGINOL® FLAKE orders will be converted to the new standard 40 LB net weight package for both parcel and palletized shipments.



## 40 LB UNIT | FPKG-40LB SPECIFICATIONS

Dimensions = 13-5/6" L X 11-15/16" W X 15" H  
Net Weight = 40 LB | Gross Weight = 44 LB

Standard Pallet Quantity = (48" X 40" X 5")  
12 Boxes Per Layer | 4 Layers | 48 Total Boxes  
Net Weight = 1,920 LB | Gross Weight = 2,104 LB

\*Package Labels are now visible in the fork facing pallet position for the new 40 LB palletizing configuration. Labels are currently NOT visible with the 50 LB unit.

## WHY CHANGE FROM 50 LB TO 40 LB?

### NEW "WEIGHT THRESHOLD"

Both FedEx and UPS have updated their weight thresholds to reduce the maximum to 50 LB gross weight from 70 LB.

A surcharge (\$24 per package) will be incurred for all packages exceeding the 50 LB "Weight Threshold".

FedEx and UPS are working with key customers to phase out standard packages over 50 LB, but it is expected that the new "Weight Threshold" will be in full effect by the end of 2020.

### HEALTH & SAFETY

The National Institute of Occupational Safety & Health (NIOSH) has a recommended weight limit of 51 LB. The new 40 LB unit will improve employee safety and health.

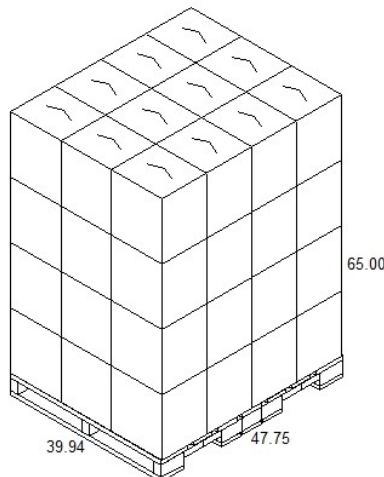

# 40 LB VS 50 LB PACKAGING COMPARISON

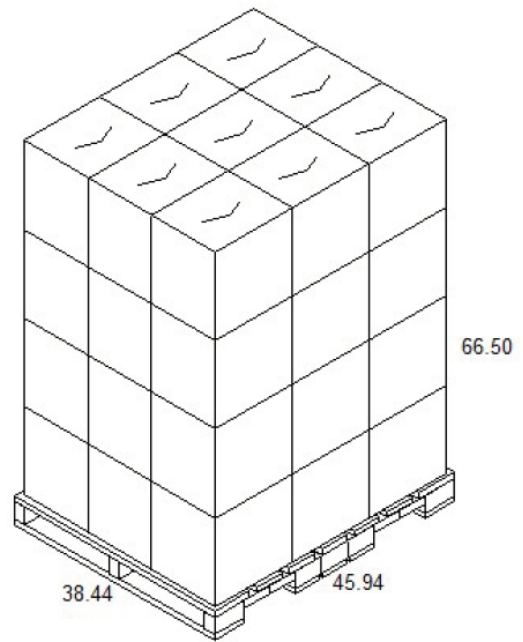
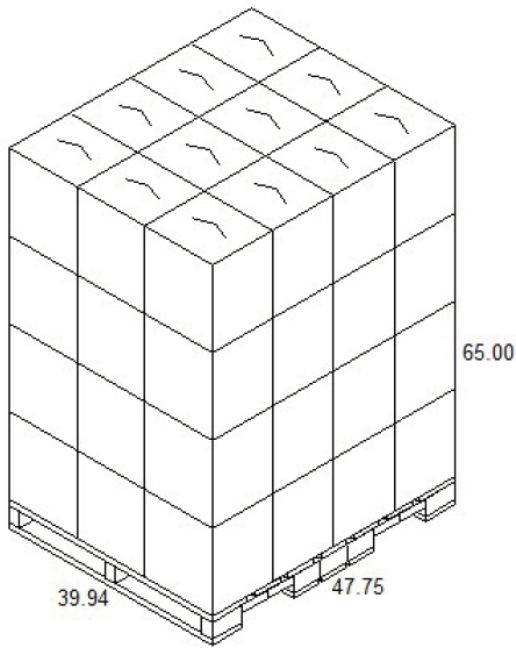

Net Weight / Unit	40 LB
Gross Weight / Unit	44 LB
Standard Pallet	48" L x 40" W x 5" H
Cases Per Layer	12
Layers / Pallet	4
Total Cases / Pallet	48
Net Weight / Pallet	1,920 LB
Gross Weight / Pallet	2,104 LB

Net Weight / Unit	50 LB
Gross Weight / Unit	54 LB
Standard Pallet	48" L x 40" W x 5" H
Cases Per Layer	9
Layers / Pallet	4
Total Cases / Pallet	36
Net Weight / Pallet	1,800 LB
Gross Weight / Pallet	1,948 LB

